

4

3

2

1

REVISIONS - BALLOONS DENOTE CHANGES			
REV.	DESCRIPTION	DATE	APPROVED
A		8/8/2017	ZAG

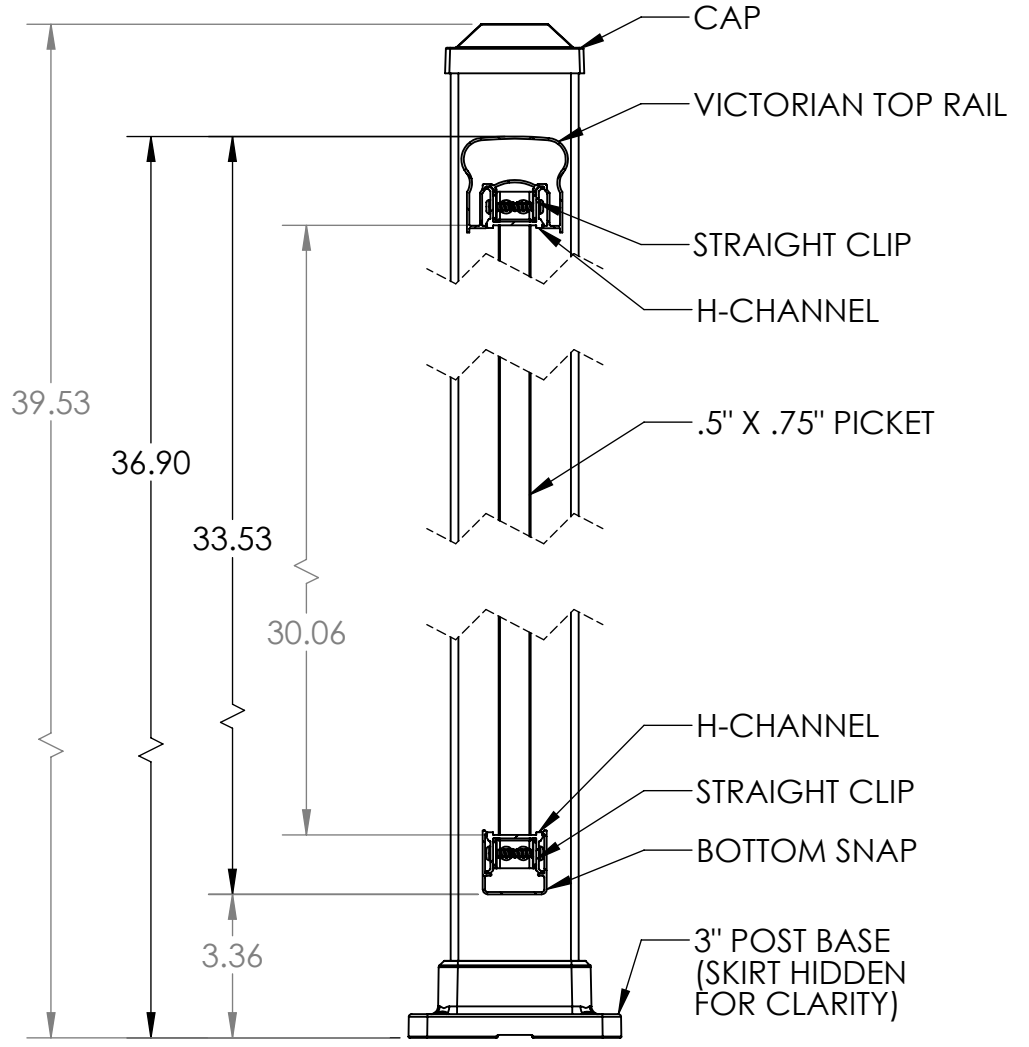
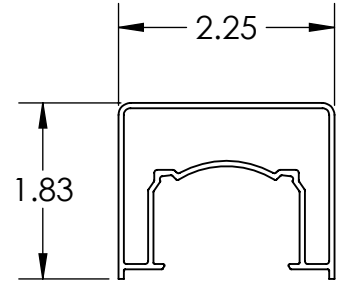
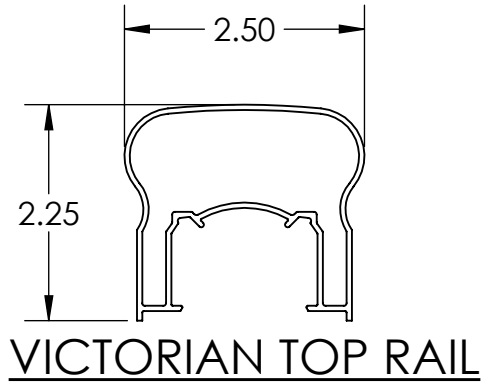
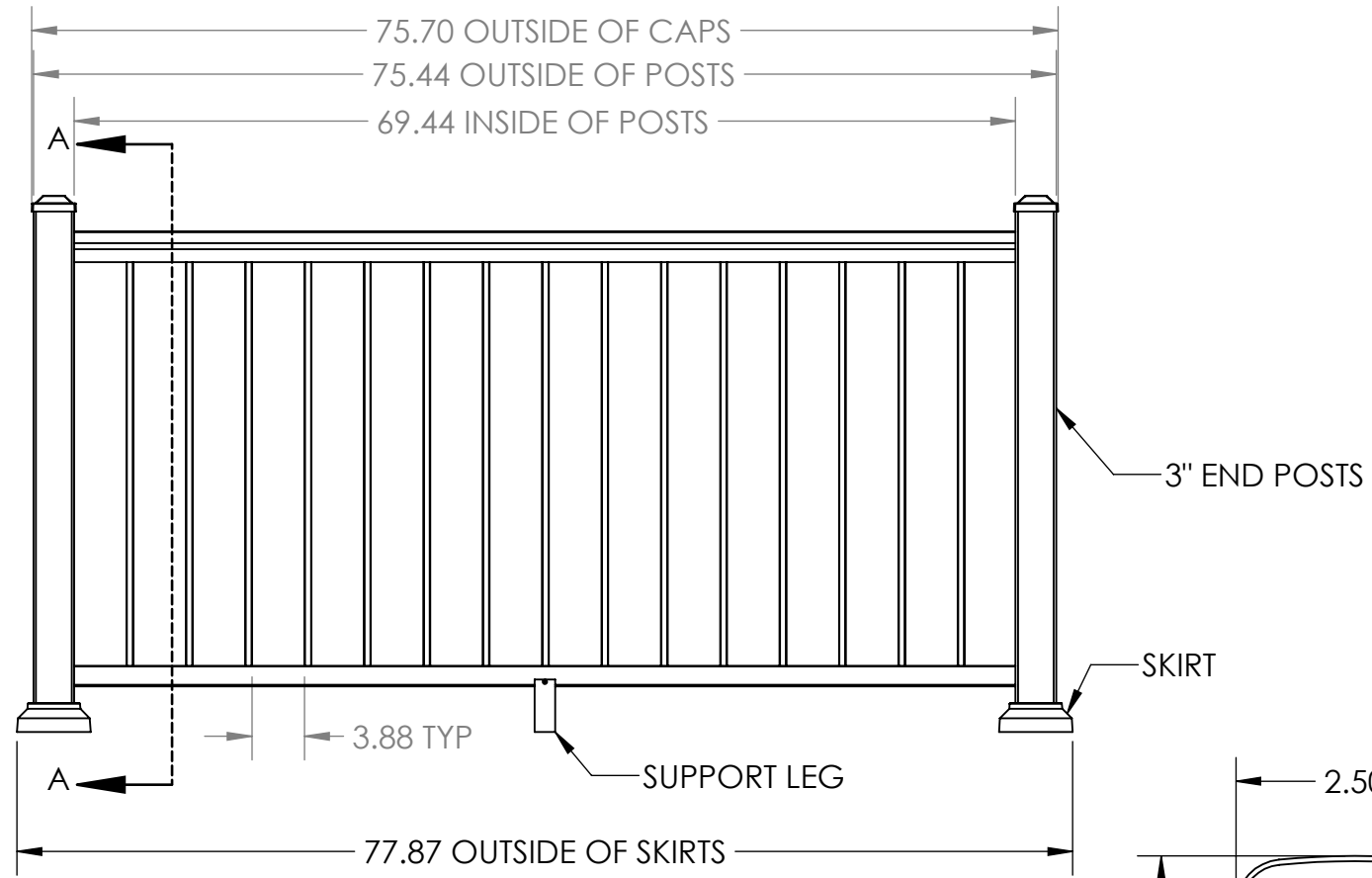

SECTION A-A

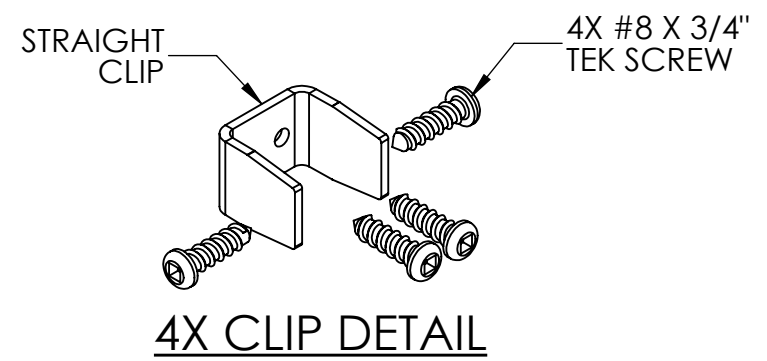

UNLESS OTHERWISE SPECIFIED:		NAME	DATE
DIMENSIONS ARE IN INCHES		DRAWN	ZAG 8/8/17
TOLERANCES:		CHECKED	
SURFACE FINISH: 125 RMS		ENG APPR.	
ANGULAR: ±.5 DEG		MFG APPR.	
LINEAR: .X ±.02		INTERPRET GEOMETRIC TOLERANCING PER: ASME Y14.5-2009	
.XX ±.010		MATERIAL	
.XXX ±.005		FINISH	
THIRD ANGLE PROJECTION:		DO NOT SCALE DRAWING	



TITLE:
POST-TO-POST 36" TOP RAIL PICKET INFILL - 3" END POSTS BASE MOUNT - 6' SECTION

SIZE	DWG. NO.	REV
B		A
SCALE: 1:10 WEIGHT:		SHEET 1 OF 1

NOTES:
1. ALL RAIL MUST BE ASSEMBLED AND FASTENED IN ACCORDANCE WITH ULTRALOX'S INSTALLATION INSTRUCTIONS.
2. AVAILABLE COLORS ARE BLACK - WHITE - BRONZE.

4

3

2

1